

P.A. – S.p.A. – EQUIPAGGIAMENTI TECNICI DEL LAVAGGIO

VIA MILANO, 13 – CASELLA POSTALE 115 – 42048 RUBIERA (REGGIO EMILIA) – ITALY
 Tel. +39 0522 623611 – Fax. +39 0522 629600 – R.E.A. RE 156319 – R.I. RE11535 – Mecc. RE 013446
 C.F. e P. IVA 01035950359 – Cap. Soc. i.v. € 750.000,00 – Codice Identificativo C.E.E. IT 01035950359
 ART. 2497 – BIS C.C. DIREZIONE E COORDINAMENTO BENETTI srl R.I. TRIB. DI RE 01480690351
 Web: <http://www.pa-etl.it> – E-mail: info@pa-etl.it



VS450-200/300 -Safety Valve

Technical Handbook: E 256
DN 32

- **60.4120.00** VS450 -200 **CE** 1"1/4 Bsp F
- **60.4130.00** VS450 -300 1"1/4 Bsp F
- **60.4120.50** VS450 -200 **CE** 1"1/4 Npt F
- **60.4130.50** VS450 -300 1"1/4 Npt F

- Intended for use with high flow rates
- Special steel spring with superior mechanical features, to maintain calibration settings for longer
- Screw/Locknut adjustment to set maximum pressure level
- Dynamic seals with O-ring and sliding gasket
- Fixing screw slots

TECNICAL DATA

Max. Flow Rate 450 l/min - Max. Temperature 90°C (1)

P/N	RATED PRESSURE	PERMISSIBLE PRESSURE	MIN. ADJUSTABLE PRESSURE	(2) PRESSURE INCREASE	INLET	BYPASS	WEIGHT
	bar - MPa	bar - MPa	bar - MPa	bar - MPa			g
60.4120.00	200 - 20	220 - 22	50 - 5	38 - 3.8	1"1/4 Bsp F	1"1/4 Bsp F	3800
60.4130.00	300 - 30	330 - 33	60 - 6	38 - 3.8	1"1/4 Bsp F	1"1/4 Bsp F	3800
60.4120.50	200 - 20	220 - 22	50 - 5	38 - 3.8	1"1/4 Npt F	1"1/4 Npt F	3800
60.4130.50	300 - 30	330 - 33	60 - 6	38 - 3.8	1"1/4 Npt F	1"1/4 Npt F	3800

(1) The valve is especially designed for a constant use at a water temperature of 60°C. It can withstand up to a max. temperature of 90°C for short intervals only.

(2) The max. pressure increase inside the valve occurs when the max. flow rate is discharged at max. calibration pressure.

Instruction, Maintenance, Installation, Spare Parts Booklet. For a correct use of the item, please follow the instructions. Please copy all relevant information on the use and maintenance booklet of the machine.	n. 12.9256.00

DIMNSIONAL DRAWING

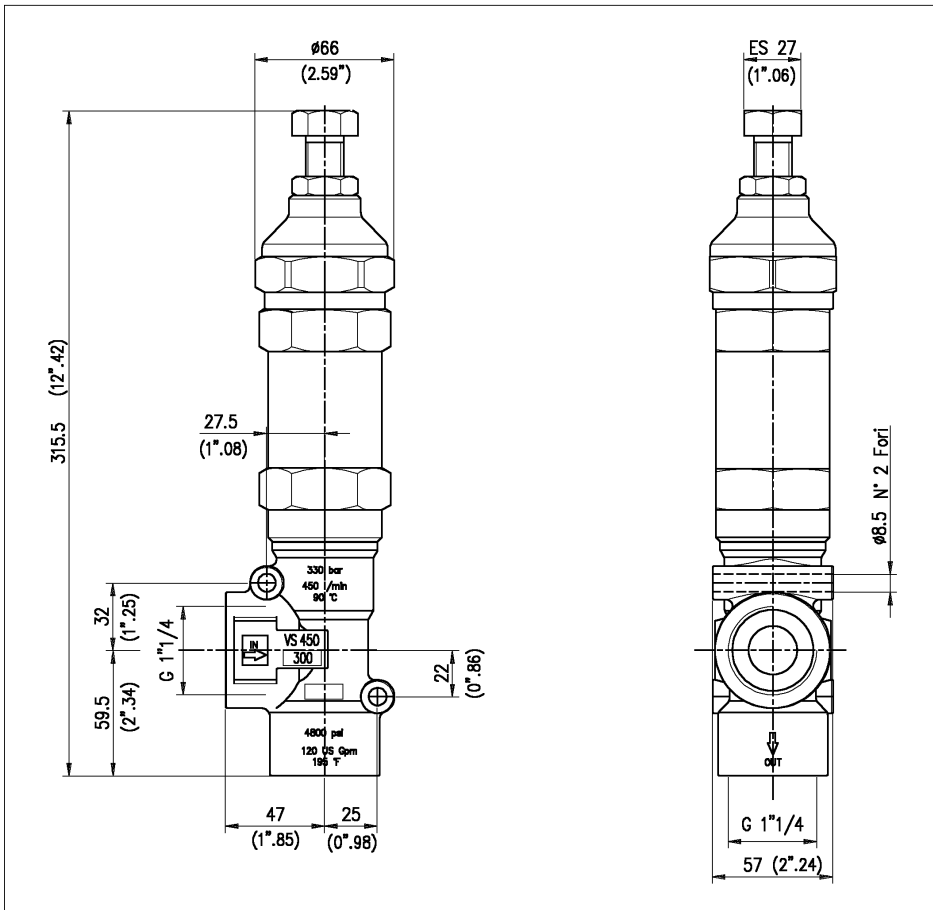

INSTRUCTIONS

SELECTION

This product is to be used with clean, fresh water, or water slightly additivated with ordinary detergents. For use involving harsh or even corrosive fluids, always ask PA Technical Department first. Appropriate filtration should be installed when using unclean fluids.

To select the right valve, always take in consideration rated running data of the system (rated pressure, max. flow rate and max. temperature). In no case shall the system pressure exceed the **permissible pressure** marked on the valve.

PRESSURE SETTING/CALIBRATION

All pressure setting must be carried out in order that pressure calibration level is lower than the max. operating pressure rate of the system and its equipment.

IMPORTANT: The nut (pos.14) must never be removed, as it is a mechanical safety device that limits the max pressure and prevents serious damage to persons and things.

DISCHARGE SYSTEM AND WATER ADDUCTION

The bypass conduct shall discharge outside of the machine or into a tank, but never directly into intake conduct. In case, it is advisable to install a baffled tank.

PROBLEM HANDLING: CAUSES AND SOLUTIONS

PROBLEMS	PROBABLE CAUSES	SOLUTIONS
Valve pulses	<ul style="list-style-type: none"> - Presence of air in the system - Seals worn out - Circuit blocked 	<ul style="list-style-type: none"> - Bleed - Replace - Clean or widen up passages
Valve does not reach desired pressure level	<ul style="list-style-type: none"> - Wrong nozzle size - Ball seat and/or shutter worn out - Nozzle worn out - Presence of material matter 	<ul style="list-style-type: none"> - Change - Replace - Replace - Clean
Pressure drops	<ul style="list-style-type: none"> - Nozzle worn out - Pump seals worn out - Valve seat worn out - Presence of air in the system 	<ul style="list-style-type: none"> - Replace - Replace - Replace - Bleed
Pressure spikes	<ul style="list-style-type: none"> - Nozzle clogged 	<ul style="list-style-type: none"> - Clean - Repeat calibration procedure and replace nozzle
Water leaking out of discharge port Valve chatters	<ul style="list-style-type: none"> - Seat O-ring worn out - Seat worn out - Presence of material matter - Pump valves worn out 	<ul style="list-style-type: none"> - Replace - Replace - Clean - Replace

MAINTENANCE

In normal working conditions the safety valve should not open (no water discharge); if the valve is fitted on the pump head, it is in any case submitted to pressure cycles which have to be calculated for maintenance.

STANDARD: every 400 working hours (approximately 10000 working cycles of the system), check and lubricate the seals with water resistant grease.

SPECIAL: every 800 working hours (approximately 20000 working cycles of the system), control the wear of the seals and internal parts and, if necessary, replace with original PA parts taking care, during installation, to lubricate with water resistant grease. Furthermore verify the absence of scale or dirt on the seat and the shutter.

ATTENTION: reassemble the valve in the correct manner paying special attention how to set the valve as described in the paragraph **PRESSURE ADJUSTMENT/SETTING**.

Maintenance has to be carried out by Specialized Technicians.

The manufacturer is not to be considered responsible for damage as a result from incorrect fitting and maintenance

Technical data, descriptions and illustrations are indicative and liable to modification without notice.

REGULATIONS : See Standard Manual.

The equipment hereby described bears the CE marking in accordance with the Rules and Directives referred to in the **Declaration of Conformity**.

For a correct use, follow the instructions given in this booklet and re-print them on the Use and Maintenance Booklet of the machine. Make sure that you are given **the original Declaration of Conformity** for the chosen item. This booklet is **applicable for all valves type VS 450-200/300**

60.4120.00 VS450/200 safety valve 1"1/4F Bsp F

60.4120.50 VS450/200 unload. 1"1/4 Npt F

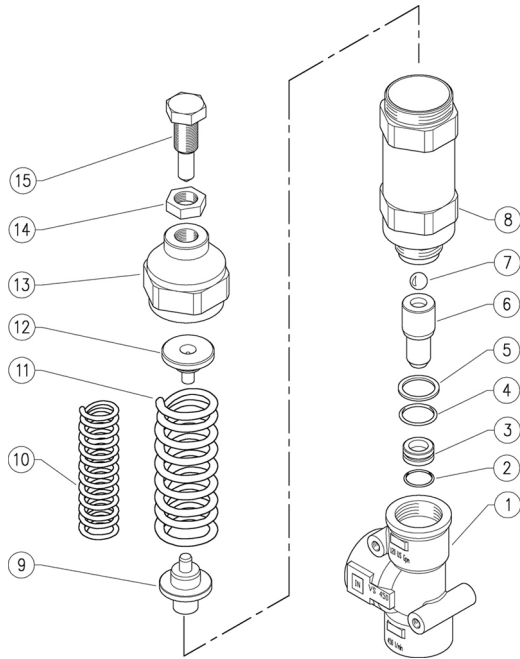

60.4130.00 VS450/300 unload. 1"1/4F Bsp F

60.4130.50 VS450/300 unload. 1"1/4 Npt F

Pos.	P/N	Description	Q.ty	K1	K2	K3	K4	
1	60.4101.35	Housing -VS450, 1"1/4 Bsp brass (1)	1					1
1	60.4111.35	Housing -VS450, 1"1/4 Npt F brass (2)	1					1
2	10.3072.01	O-ring, 1,78x20,35 mm Ni 85	1	•				10
3	60.4109.51	Seat, 15x23,5x10 mm Sst.	1	•				3
4	10.3244.00	O-ring, 3,53x24,99 mm	1	•				10
5	10.4097.00	Back-up ring, 25x31,2x2mm	1	•				5
6	60.4108.51	Piston -VS450, Sst.	1	•				3
7	14.7465.00	Ball, 1/2" Sst.	1					5
8	60.4106.31	Piston holder, M 36	1					1
9	60.4103.31	Ball holder	1					3
10	60.4110.61	Spring, 5,5x15,5x94mm (1)	1					3
11	60.4102.61	Spring, 10,5x33,5x119mm	1					3
12	60.4105.31	Spring guide	1					3
13	60.4104.31	Plug, M 52 brass	1					3
14	11.4850.08	Nut, M 18 Sst.	1					3
15	60.4107.51	Screw, M18 Sst.	1					5

Kit	P/N	Description	
K1	60.4122.24	Spares kit -VS 450/200-300, 5x1pcs.	1

(1) 60.4130.00 (2) 60.4130.50