



CAVIBLASTER[™]

CAVIDYNE[™], LLC
5077 Fruitville Rd., Suite
109-157 Sarasota, FL 34232
Phone: (352) 275-5319

Operation & Maintenance Manual



Model 1625-D



CAVIDYNE™, LLC is not responsible for damages or injuries resulting from a failure to comply with instructions in this manual. Please read entire manual carefully before use.



The CaviBlaster™ 1625-D must only be operated and maintained by trained personnel.



This equipment generates high pressure water and is intended for underwater use only. **Serious personal injury or death may result from improper use.**



Commercial Diver's gear should be used to operate the CaviBlaster™ system.



CAUTION: DO NOT USE THIS EQUIPMENT TO CLEAN SENSITIVE SURFACES as LED-Lights, Underwater Lights, Electronic Equipment, Etc.

TABLE OF CONTENTS

1.0 UNIT SPECIFICATIONS.....	4
2.0 GENERAL DESCRIPTION.....	5
2.1 Using this Manual.....	9
2.2 Conventions.....	9
2.3 Scope.....	9
2.4 Terms and Abbreviations.....	10
3.0 SAFETY INFORMATION.....	11
3.1 Personal Safety.....	11
3.2 Personal Protective Equipment.....	12
3.3 Modification to the Equipment.....	13
4.0 INSTALLATION.....	14
4.1 Uncrating and Lifting.....	14
4.2 Installation Location.....	15
4.3 Initial Set Up.....	16
4.3.1 Connecting the Battery Terminals.....	16
4.3.2 Connecting the Water Source.....	18
5.0 OPERATION.....	23
5.1 Preparing the Unit for Operation.....	23
5.2 Startup.....	24
5.3 Normal Operation.....	25
5.4. ZT-Gun / CaviDome™ Pressure Calibration.....	26
5.5. Recommendations for Effective Cleaning Results.....	28
6.0 MAINTENANCE.....	31
6.1 Basic Preventive Maintenance Recommendations.....	32
6.2 Diesel Engine Service.....	33
6.3 Pump Service.....	33
6.4 Inspection / Cleaning of water inlet strainer.....	33
8.0 TROUBLESHOOTING.....	36
9.0 REPLACEMENT PARTS.....	38
APPENDIX - COMPONENT LITERATURE.....	39

1.0 UNIT SPECIFICATIONS

The CaviBlaster™ 1625-D power unit consists of a 32.8 HP Kubota V1505-E3B diesel power-pack and a UDOR NX-C-55/200R positive displacement pump. Detailed performance and specifications are listed below:

CaviBlaster™ 1625-D Specifications	
Nominal Pump Flow	16 GPM (61 LPM)
Operating Pressure	2,500 PSI (172 BAR)
Engine (New, Tier-4)	32.8 HP Diesel Powered (Kubota D1105-T)
Installation Environment	Outdoor enclosed or exposed <i>See Section 4 for installation requirements</i>
Fuel Requirements	Diesel fuel (ASTM Grade No. 1-D or 2-D)
Fuel Tank Capacity	6.5 Gallons (24.5 Liters)
Water Inlet Pressure Limits	0 PSI (Atmospheric Pressure) to 50 PSI Maximum (0 BAR to 3.5 BAR) <i>See Section 4 for further requirements</i>
Overall Unit Dimensions (L x W x H)	56" x 24" x 42" (142 cm x 61 cm x 106 cm)
Maximum Pressure Hose Length	600 LF (200 meters) of 3/4" diameter thermoplastic
Power Unit Weight (Dry)	800 LBS (362 KG)
Zero-Thrust Gun Weight	13 LBS (5.9 KG)

Figure 1.1 – CaviBlaster™ 1625-D Specifications

(EOS)

2.0 GENERAL DESCRIPTION

The CaviBlaster™ 1625-D high-pressure water power unit allows the operator to use the water flow and pressure to generate cavitation at the end of the proprietary nozzle.

The CaviBlaster™ cleans the surface of any underwater structure using the energy released by the implosion of the bubbles during the cavitation process. When directed at the surface being cleaned, the energy released by the collapsing bubbles causes marine growth to be removed from the surface.

The system consists of a Cavitation tool connecting a high-pressure hose and a diesel-powered and a high-pressure pumping unit.

- ➔ The Zero Thrust Gun or **ZT-Gun** uses a trigger-operated valve to control the water stream On and Off. If the valve is closed, the power unit goes into bypass mode unloading the engine and the pump.
- ➔ The **CaviDome**™ also uses a trigger-operated valve to control the water stream On and Off. If the valve is closed, the power unit goes into bypass mode unloading the engine and the pump.
- ➔ The **CaviBlaster**™ **Lance** does not have a trigger-operated valve, the control of the water stream is done turning the surface unit On or Off, It will run constantly while the unit on the surface is On.

Cavitation Tools



ZT-Gun



CaviDome



ROV Lance

	<p>FULL LOAD is defined as the engine at full throttle / full speed. If partially throttled, the engine will stall, creating an undesirable running condition for the centrifugal clutch.</p>
---	---

The CaviBlaster™ 1625-D power unit is a complete “plug and play” system built into a self-supporting frame that allows quick deployment and / or installation of the unit. Water can be supplied from either a pressurized source, directly from the natural source via an electric booster pump supplied with the power unit, or from a gravity storage feed tank.

The unit is equipped with many features to maintain operator safety while operating at pressures of 2,500 PSI (172 BAR).

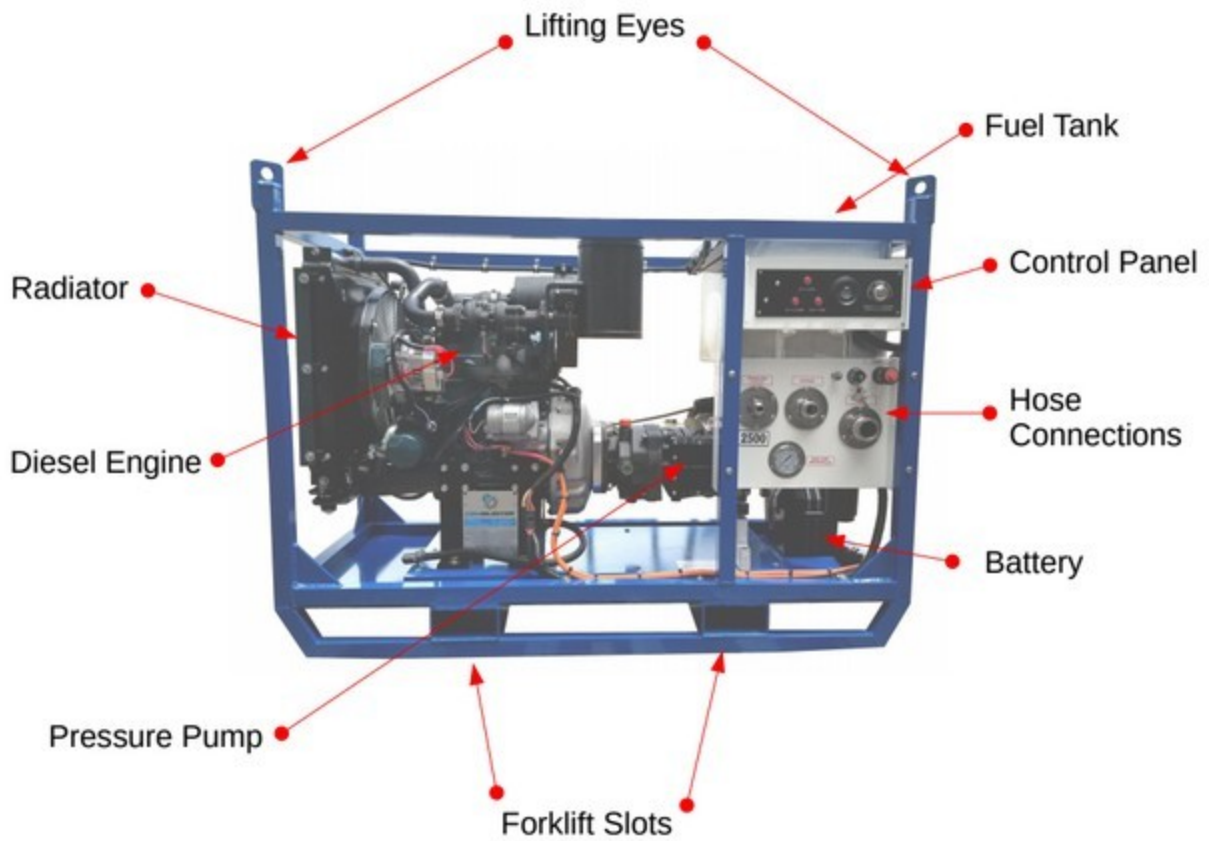

Figure 2.2 – CaviBlaster™ 1625-D General Features

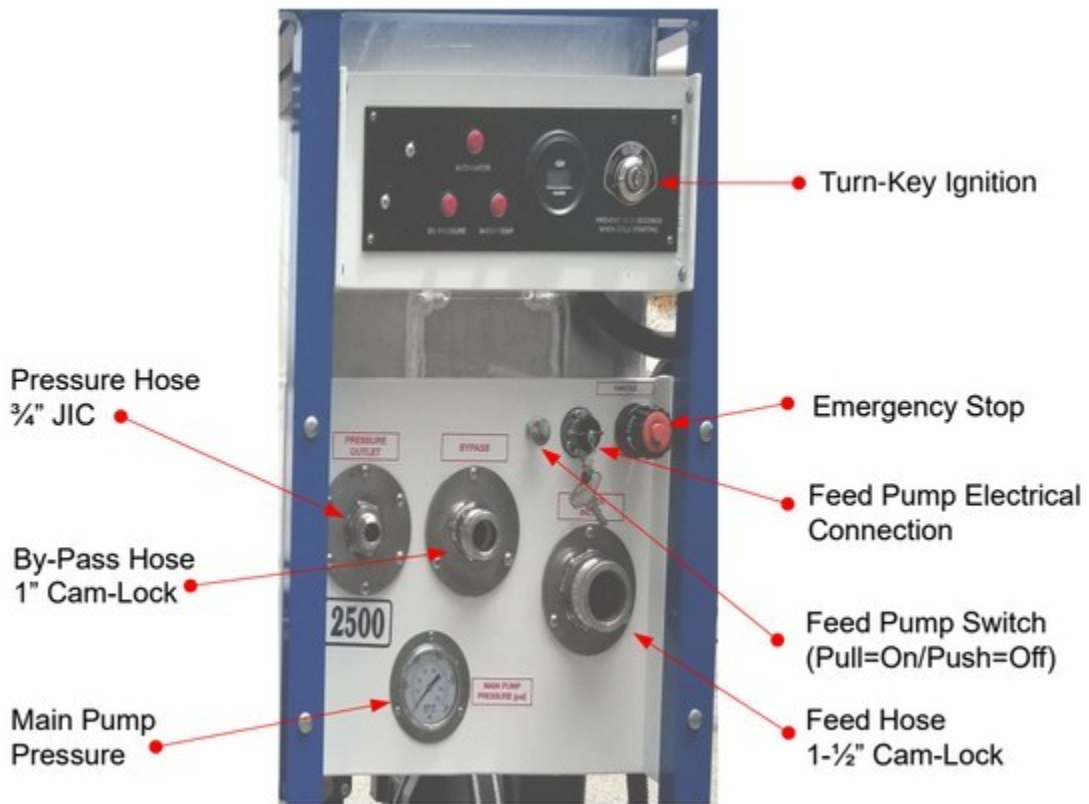

Figure 2.3 – CaviBlaster™ 1625-D Control Panel

2.1 Using this Manual

Every attempt has been made to ensure that this documentation is complete and accurate at the time of publication. It is imperative; however, that anyone attempting to use this manual must have good comprehension of how this equipment operates. Further, this manual can in no way replace the common sense of an individual. If at any time this manual seems to contradict itself, or common sense, discontinue the procedure, re-read the section, and seek assistance from CAVIDYNE™, LLC or other personnel familiar with the operation of this equipment.

2.2 Conventions

The first time a component is mentioned, it is typically followed by a figure reference; e.g., Emergency Stop button (See Figure 2.1). Figure numbers and section numbers are always coincident.

When other sections are referenced the *SECTION NAME* will appear in caps and italics. The electronic version allows users to click on the section name or figure reference to jump to that section. The words "This space intentionally left blank" will appear where there is more than 3 inches of white space.

(EOS) will appear above the page number on the last page of each section.

2.3 Scope

This manual covers installation, operation, and maintenance of the CaviBlaster™ 1625-D. It is essential that personnel who will operate and / or service this equipment familiarize themselves with this manual. Standard components, such as the unit engine and pump, are covered by the manufacturer's literature found in the Appendix.

2.4 Terms and Abbreviations

CCW	Counterclockwise
CW	Clockwise
EOS	End of Section
GPM	Gallons Per Minute
HP	Horsepower
LPM	Liters Per Minute
PPE	Personal Protective Equipment
PSI	Pounds Per Square Inch (without suffix, assumed to be gauge pressure).

(EOS)

3.0 SAFETY INFORMATION

The CaviBlaster™ 1625-D power unit is an inherently powerful and potentially dangerous piece of equipment; however, with proper care and training it can be operated safely. The CaviBlaster™ 1625-D must only be operated by personnel that have read and understand this manual. It is intended to reinforce and review safety techniques to prevent personal injuries and property damage.

Users must comply with all local, state, and national laws concerning high-pressure water jetting equipment as well as all underwater work regulations.

It is strongly recommended that this entire manual be reviewed in-depth before operating or servicing this equipment. Service work should only be performed by individuals who are proficient in using this equipment. Refer to the applicable section in this manual for the correct procedures prior to any installation, setup, or maintenance work.

3.1 Personal Safety

Operation of the CaviBlaster™ 1625-D underwater cleaning system must only be attempted by commercial divers or other personnel who have been trained in its use. Appropriate protective equipment should always be worn. Operation of the system without the proper equipment and training can result in personal injury.



CAVIDYNE™, LLC is not responsible for damages resulting from a failure to comply with instructions in this manual. Please read carefully before use.



If maintenance or repair of the **ZT-Gun** is being conducted out of the water, remember that the Zero-Thrust Gun has front and rear jets. Never direct the jet streams at a person or animal. Never direct the jet streams toward power lines or other high voltage equipment.



If maintenance or repair of the **CaviDome™** is being done out of the water, remember that the **CaviDome™** has rotating nozzles at high speed. Never put your hands or any objects in contact with these nozzles.



When installing the **CaviBlaster™ Lance** onto the ROV make sure the CaviBlaster™ unit is not running, and before testing assure the stream of water is pointing into a safe direction, where no damage can be done, preferable underwater.



Ensure that there is a safe area to work while operating the CaviBlaster™ 1625-D.



Seek immediate medical attention if the operator suffers an injury as the result of contact with the high-pressure water stream. **Serious personal injury can result from an untreated water injection wound.**

3.2 Personal Protective Equipment

Always wear appropriate Personal Protective Equipment (PPE) when operating this equipment.

Personnel operating or working in the vicinity of the power unit should wear appropriate hearing protection when the CaviBlaster™ system is in use. If the diver is not wearing a diving helmet, hearing protection is recommended. CAVIDYNE™, LLC recommends wearing vented earplugs such as “Doc’s Pro-plugs” for diver hearing protection.

The operators of the CaviBlaster™ system should always wear neoprene or heavy rubber gloves to provide protection to the hands and, in particular, to the nails. The gloves will absorb most of the energy produced by bursting cavitation bubbles and prevent the cavitation bubbles from contacting the operators’ hands.

The gloves will also protect operators' hands from the initial shock wave when the ZT-Gun / CaviDome™ is activated.



Failure to wear appropriate PPE may result in personal injury.

3.3 Modification to the Equipment

Do not make any unauthorized modifications or repairs to this equipment. Components used throughout this assembly were specifically designed or selected to safely meet the unique high-pressure requirements. Only replace parts with those recommended by or supplied by CAVIDYNE™, LLC. Any unapproved modifications will void the equipment warranty. Unauthorized modification or part substitution can result in serious personal injury or property damage.



Unauthorized replacement of any part may lead to catastrophic equipment failure and serious personal injury.

(EOS)

4.0 INSTALLATION

The CaviBlaster™ 1625-D must be installed in accordance with the requirements outlined below. The unit can be installed in a vehicle to allow for maximum mobility and flexibility.

4.1 Uncrating and Lifting

Unpack the equipment and inspect for damage. If damage is found, immediately contact CAVIDYNE™, LLC and the shipping company. If the unit will not be installed immediately, provide adequate indoor storage to protect against damage.

The CaviBlaster™ power unit should be lifted from underneath the frame using the forklift channels or by using the lifting eyes provided on top of the frame. Verify that lifting equipment is rated for the weight listed in Section 1.0 UNIT SPECIFICATIONS and that the unit is stable before lifting.

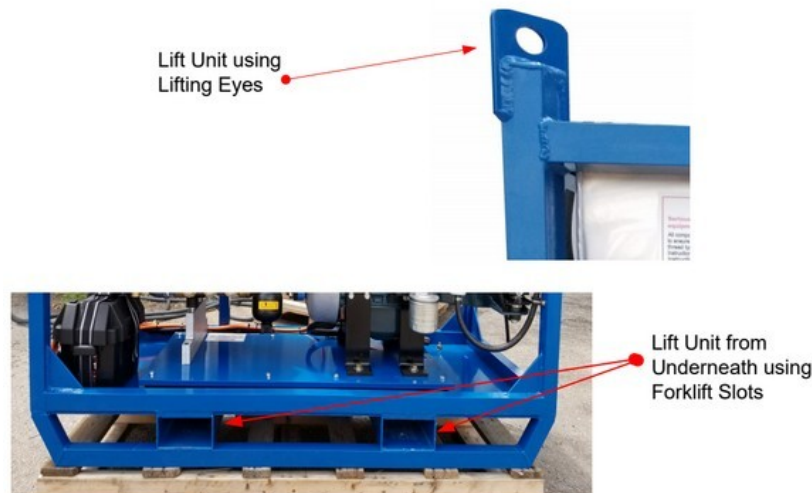

Figure 4.4 – Lifting Guidelines

4.2 Installation Location

For maximum flexibility the CaviBlaster™ power unit should be installed in an area where it is capable of reaching both its water source and anticipated cleaning targets within acceptable hose lengths. The CaviBlaster™ power unit can be installed in an enclosed* or open environment.

* Enclosed installations will require provisions for adequate engine cooling air flow and for venting of engine exhaust. See Figure 4.5 below.

Installation location must be a level surface able to safely support the unit weight listed in Section 1.0 UNIT SPECIFICATIONS. Orient unit to allow unrestricted access to the hose connection plate and control panel, located on the front of the unit. Allow a minimum of three feet behind the unit and access from above to conduct service and repair work. Take note of frequently serviced areas such as the engine and fuel tank.

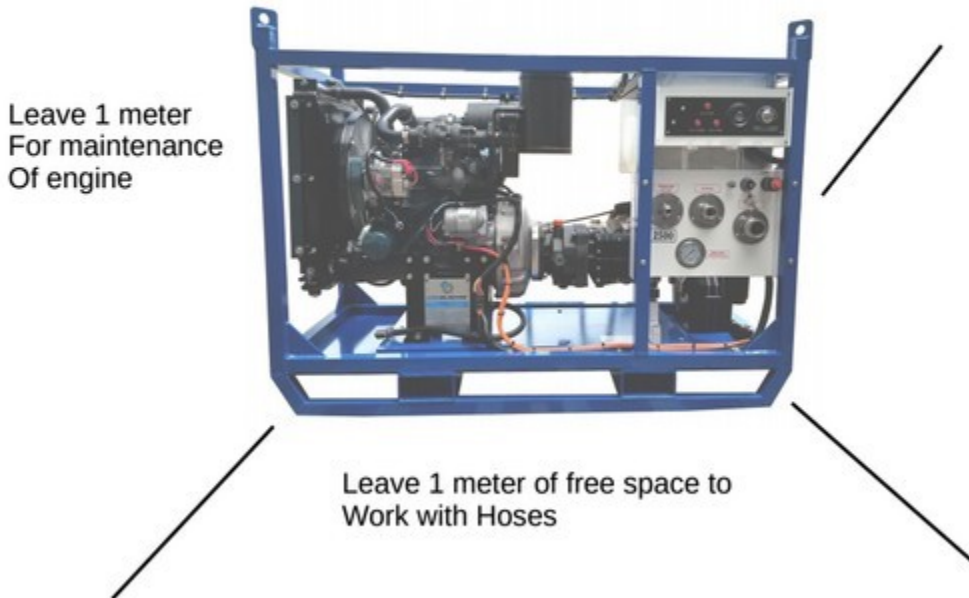

Figure 4.5 – Installation Guidelines

4.3 Initial Set Up

After first receiving the CaviBlaster™ power unit, the following must be checked and completed:

- 1) Connect the battery (See Section 4.3.1).
- 2) Add engine oil (See Engine Manual located in the APPENDIX).
- 3) Add engine coolant (See Engine Manual located in the APPENDIX).
- 4) Add pump oil (See Pump Manual located in the APPENDIX).
- 5) Connect the feed or suction hose (See Section 4.3.2).
- 6) Connect the bypass hose (See Figure 2.2).
- 7) Connect the pressure hose (See Figure 2.2).
- 8) Connect the electric feed pump (See Section 4.3.2).
- 9) Fill the fuel tank (See fuel requirements in Engine Manual located in the APPENDIX).



Engine and / or pump fluids may have been removed for shipment. Check fluid levels prior to starting.

4.3.1 Connecting the Battery Terminals

For shipping purposes, the battery terminals have been disconnected. To reconnect the battery, reference Figure 4.3 and the procedure below:

1. Push IN the Emergency Stop button located on the front control panel (See Figure 2.2).
2. Open the battery box by loosening the strap and removing the cover.
3. Connect the battery terminals as follows:
 - RED** to positive terminal
 - BLACK** to negative terminal
4. Tighten the terminal screws securely.
5. Replace the battery cover and secure with strap.

1-Main Battery Location



2-Remove Protection Cover



3-Locate Cables

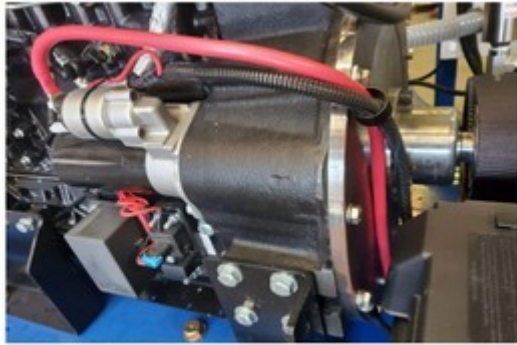

Black=Negative / Red=Positive

4-Connect Terminals



Positive
RED

Negative
BLACK

Figure 4.3 – Reconnecting the Battery Terminals

4.3.2 Connecting the Water Source

The CaviBlaster™ power unit can be used with seawater or fresh water. It must be flushed with fresh water for 1-2 minutes after each use in seawater to ensure long service life.



The CaviBlaster™ 1625-D must be flushed and rinsed with fresh water after every use in seawater.



Failure to flush and rinse the power unit after use in seawater will result in increased wear and tear on components and in decreased service life.



Failure to flush and rinse the unit can cause the pump valve(s) to stick in the open position. This will prevent the system from producing the correct operating pressure.

The feed water inlet connection is located on the front control panel of the CaviBlaster™ 1625-D (see Figure 2.2). Two water supply conditions are acceptable for the CaviBlaster™ Power Unit.

- Gravity feed water source: - CAVIDYNE™, LLC feed pump system not required (see Figure 4.4). Requires connection hose with a minimum diameter of 1-¼" between the water tank and the Power Unit and must be above the main pressure pump inlet. The gravity feed system must be capable of consistently providing at least 30 GPM (114 LPM).
- Forced inlet water condition:
 - a) Outside Water Source (Pressurized) – Must be capable of consistently providing at least 30 GPM (114 LPM) at a maximum pressure of 50 PSI (3.6 BAR).
 - b) Feed Pump System provided with your CaviBlaster™ Power Unit.

Two versions of feed pumps are provided with various Models of CaviBlaster™ 1625-D Power Units:

- 1) Submersible Feed Pump Hose Assembly (electric 12 V) System: Powered by the system's battery and controlled by manual ON / OFF pull switch located on the control panel. Capable of providing 30+ GPM, at a maximum lift (head) of 6 feet (2 meters).
- 2) Centrifugal Suction Feed Pump (belt-driven): self-prime up to 6 feet (2 meters), constant flow. Capable of providing 30+ GPM up to 20 feet (6 meters) after primed.

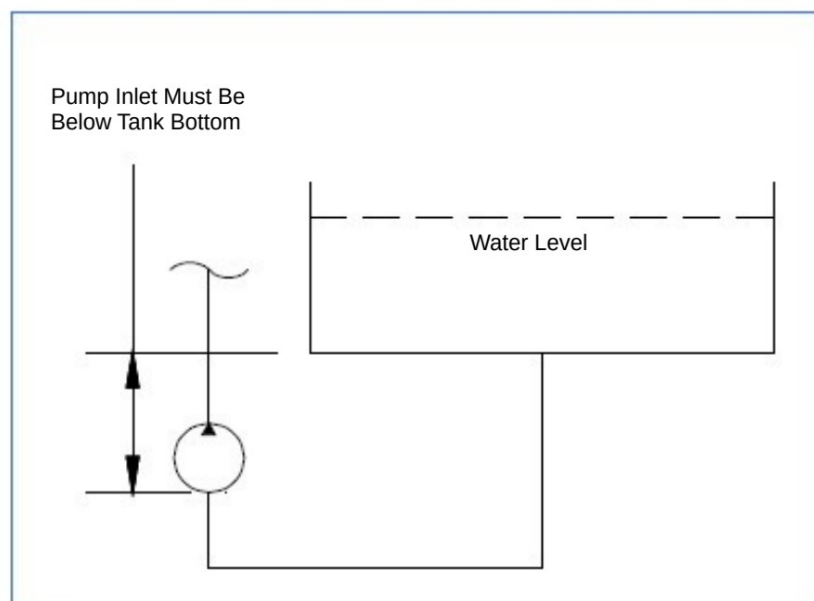

Figure 4.4 – Gravity Feeding Source

To use force feed:

- Turn the engine ignition key to OFF.
- Push IN the Emergency Stop button to ensure that power to the engine has been disconnected. (Fig. 4.5).
- Connect the cam-lock socket on the 1" clear PVC feed hose to the water inlet connection on the control panel (Fig. 4.6).
- Connect the electrical plug on the feed pump power cable to the matching receptacle on the control panel (See Fig. 2.2).
- Submerge the feed pump into the water source.
- Release the Emergency Stop button.
- Pull the feed pump ON / OFF switch out to activate the feed pump (See Fig 4.6).
- It is important not to operate the feed pump for long periods of time without the engine operating as this will discharge the battery.
- Apply appropriate hearing protection prior to starting engine. Insert the key into the ignition switch on the control panel (Figure 2.2). Turn the key clockwise one position to heat the glow plugs. Once the two red lights to the left of the ignition switch are ON, turn the key farther clockwise to start the engine.

To use gravity feed:

- Locate the water supply tank so that the bottom of the tank is higher than the water inlet on the control panel (Figures 4.4 and 4.6).
- Turn the engine ignition key to OFF.
- Push IN the Emergency Stop button to ensure power has been disconnected. (Fig. 4.5).
- Connect a 1" hose to the water inlet 1" cam-lock plug.
- Connect the other end of the hose to the water supply tank.
- Make sure the lowest point in the hose line is the connection with the power unit.
- Release the Emergency Stop button.
- It is essential that adequate water is supplied to the water supply tank to maintain the water level several inches above the bottom of the tank. Failure to maintain an adequate water level in the supply tank could starve the pressure pump of water causing damage to the seals or other components of the pressure pump.

Ensure that the water source can reliably deliver the maximum pump flow of 20 GPM (76 LPM). A minimum flow of 30 GPM (114 LPM) is recommended to ensure that the pump is not starved of water. If connecting to a tank, locate the bottom of the tank above the water inlet connection on the power unit to ensure a flooded suction line. (See Figure 4.4)

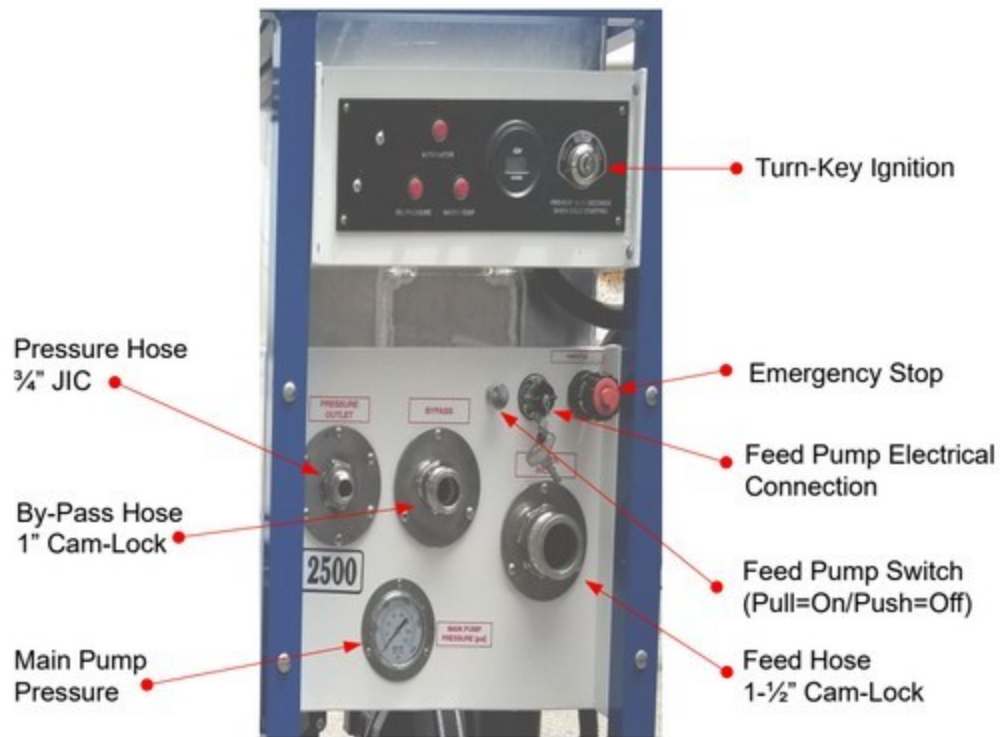

Figure 4.5 – Emergency Stop Button

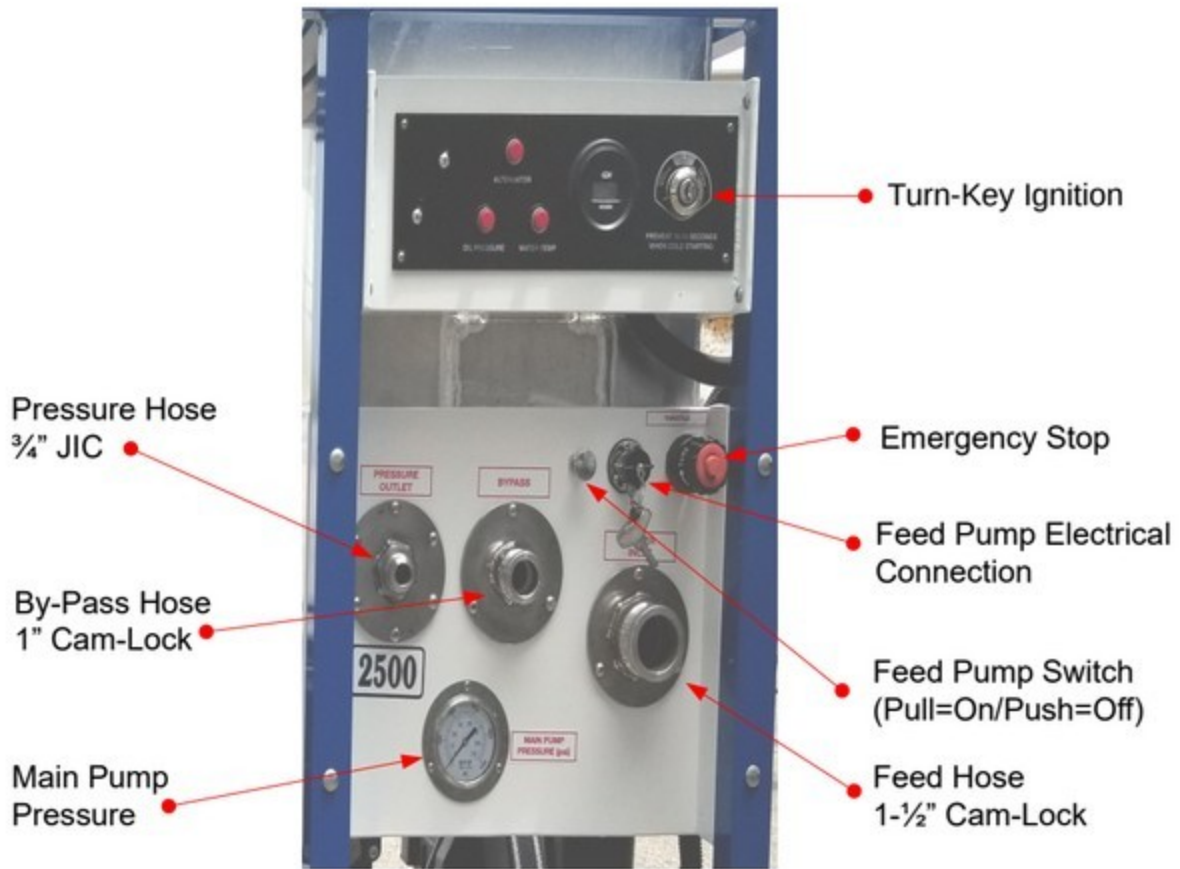

Figure 4.6 – Connecting the Water Source / Feed pump

(EOS)

5.0 OPERATION

The CaviBlaster™ 1625-D should be operated by two (2) properly trained individuals. One, the diver who operates the ZT-Gun / CaviDome™, and an operator who handles the power unit. Both operators should be in audio or visual communication with each other. If the system is connected to a Lance, the ROV operator will be in charge of handling the Lance with the ROV to do the cleaning.



The CaviBlaster™ 1625-D should only be operated by properly trained personnel who are familiar with the contents of the manual. Review the safety requirements found in Section 3 before operating.

5.1 Preparing the Unit for Operation

The following checklist should be completed in advance, so that the unit is always ready for immediate use. This should be completed after each use.

- 1) Check the engine oil. (See engine manual found in the APPENDIX).
- 2) Check the pump oil. (See pump manual found in the APPENDIX).
- 3) Check the water inlet strainer. (See Figure 6.1).
- 4) Check the fuel tank (See Fig. 4.5).
- 5) Inspect the hose and JIC fittings.
- 6) Connect / Install the ZT-Gun / CaviDome™ / Lance

5.2 Startup

Before starting the CaviBlaster™ 1625-D power unit, review all safety requirements found in Section 3. This equipment should only be operated by individuals who have read and understand the CaviBlaster™ Operation and Maintenance Manual.

- 1) Verify that the unit has been properly prepared for operation as described in Section 4.
- 2) Verify that the ZT-Gun / CaviDome™ / Lance is properly connected and the mechanical trigger is released.
- 3) Verify that the Emergency Stop button (See Figure 2.2) is released by twisting and pulling it out.
- 4) Verify that the throttle cable is fully depressed (See Fig. 5.1).
- 5) **Apply appropriate hearing protection prior to starting engine.**
- 6) Insert the key into the ignition switch on the control panel (See Figure 2.2). Turn the key clockwise one position to heat the glow plugs. Once two of the three red lights above and to the left of the ignition switch are on, turn the key farther clockwise to start the engine.



DO NOT THROTTLE UP THE ENGINE UNTIL THE DIVER IS READY FOR UNDERWATER OPERATION.



The engine must be run at full throttle / full speed. If partially throttled, the engine will stall, creating an undesirable running condition.

5.3 Normal Operation

Normal operation of the CaviBlaster™ system is defined as user control of water flow via the ZT-Gun / CaviDome™ trigger. Control of the power unit from the ZT-Gun / CaviDome™ trigger is accomplished by a mechanical shut-off valve in the tool. Should a problem develop with the control valve, discontinue using the CaviBlaster™ tool until fixed.

The CaviBlaster™ 1625-D is designed to operate in two modes: Idle and Full Throttle. Less than full throttle will result in malfunction of the belt drive system and the performance of the centrifugal clutch.



Review the safety requirements for PPE and safe operation before proceeding.

- 1) Startup the power unit as described in Section 5.2.
- 2) Unroll sufficient length of hose and bring the ZT-Gun / CaviDome™ / Lance to the operating location.
- 3) Pull trigger to allow full water flow. ZT-Gun / CaviDome™
- 4) Throttle the engine up by completely pulling the throttle cable all the way out and twisting to lock it (See Fig. 5.1).
- 5) Release trigger to stop the water flow and direct to bypass.



Releasing the ZT-Gun / CaviDome™ trigger will unload the engine, but keep it at full throttle.

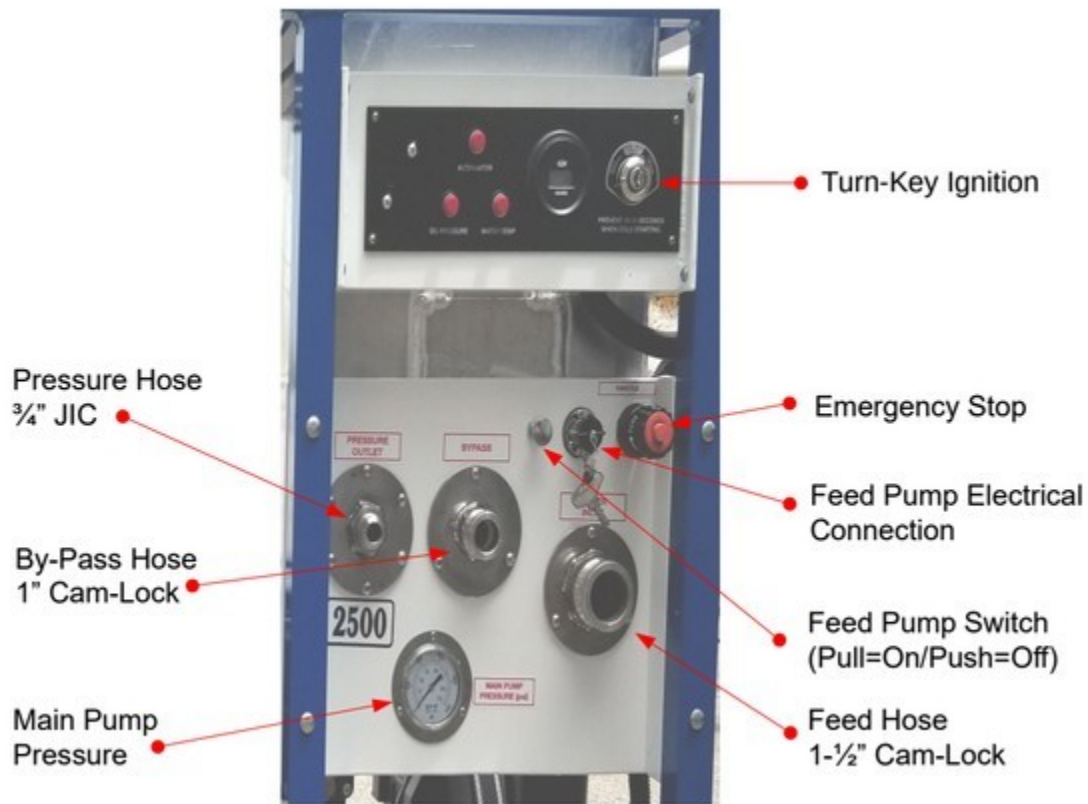

Figure 5.1 – Engine Throttle Control

5.4. ZT-Gun / CaviDome™ Pressure Calibration

The pressure at the nozzles has to be maintained within certain limits to achieve cavitation and for best performance results. If cleaning performance degrades, or every 3 months at a maximum, repeat this calibration procedure for best results.



A CALIBRATION TEST GAUGE IS RECOMMENDED WITH EVERY UNIT. CONNECT BETWEEN THE END OF THE THERMOPLASTIC HOSE AND THE TOOL.

To check / calibrate the pressure at the ZT-Gun / CaviDome™, follow the procedure below:

- Stop the power unit and pull the tool trigger to discharge any residual pressure in the hose lines.
- Disconnect the CaviBlaster™ tool with its whip hose from the main hose line.
- Attach the calibration gauge and tighten the JIC connections.
- Pull the mechanical trigger.
- Start the power unit (Section 5.2).
- Throttle the engine to full speed (Section 5.3).
- Hold the CaviBlaster™ tool tight and observe the gauge (Figure 5.2).
- Turn the knob on top of the pressure regulating valve until pressure reads 2,500 PSI (172 BAR) on the test gauge. Turning the knob clockwise will increase the pressure and turning it counter clockwise will decrease the pressure.



DO NOT ADJUST THE PRESSURE TO MORE THAN 2,500 PSI (172 BAR) AT THE TOOL. HIGHER PRESSURE WILL NOT IMPROVE PERFORMANCE.



HOSE LINES ARE RATED FOR 3,000 PSI. PRESSURES ABOVE 3,000 PSI COULD RESULT IN HOSE FAILURE.



DO NOT PUT YOUR HAND OR ANY OBJECT IN FRONT OF THE JET STREAMS OR IN THE ROTATING NOZZLES.



DO NOT RUN THE CaviDome™ OUTSIDE OF WATER FOR LONG PERIODS OF TIME, THE SYSTEM IS DESIGNED TO ALWAYS RUN UNDERWATER.

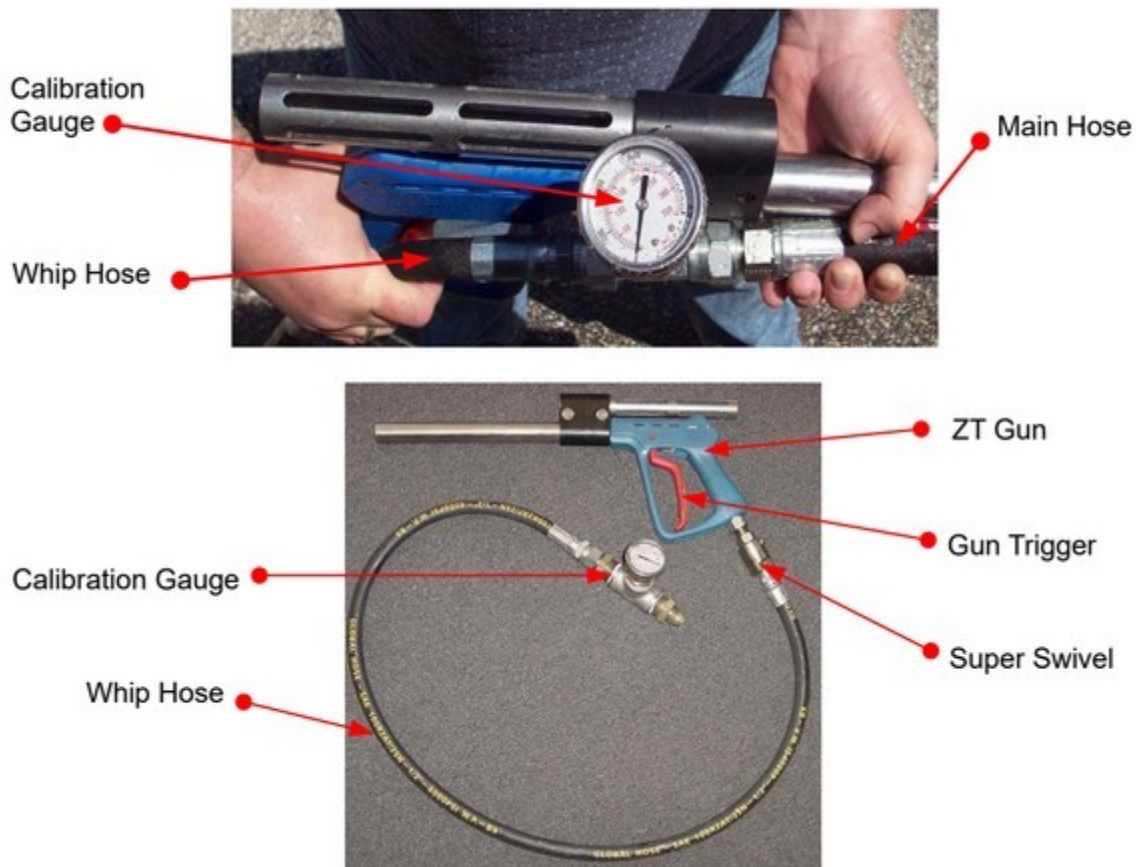

Figure 5.2 – ZT-Gun Pressure Calibration

5.5. Recommendations for Effective Cleaning Results

ZT-Gun. Once the engine is throttled up to operating speed and the ZT-Gun trigger is pulled, the diver has to find the most effective distance between the nozzle and the surface being cleaned.

CaviDome™. With the CaviDome™ once it has been placed over a flat surface it is always better to move it on a straight line on top of the surface being cleaned, avoiding obstacles to protect the rotating nozzles and the sensible parts of the hull.

When the diver is ready to commence cleaning operations, ensure that the ZT-Gun / CaviDome™ trigger is in the open or “ON” position (Figure 5.3), the tool is submerged in the water and the feed pump is operating prior to throttling up the engine. Ensure that the power unit operator and other people working in the vicinity of the power unit wear appropriate hearing protection when the engine is running.

1. Engage the pressure pump by pulling the engine throttle lever (Figure 5.1) to the operating speed position (fully extended) to engage the centrifugal clutch. Tighten the thumb screw to hold throttle in operating speed position.
2. The most efficient operating technique with the ZT-Gun is to hold the nozzle 2-5 inches away from the surface to be cleaned and at a 25 to 45 degree angle to the surface (Figure 5.3). The diver needs to observe the shape of the cavitating jet cone. At greater depths, the higher ambient pressure will cause the jet cone to be shorter. The widest zone of the cone is the most efficient part of the cavitating jet. Placing the nozzle closer than 2 inches from the surface being cleaned will not allow for efficient cavitation performance and will degrade the cleaning capability of the CaviBlaster™ system.

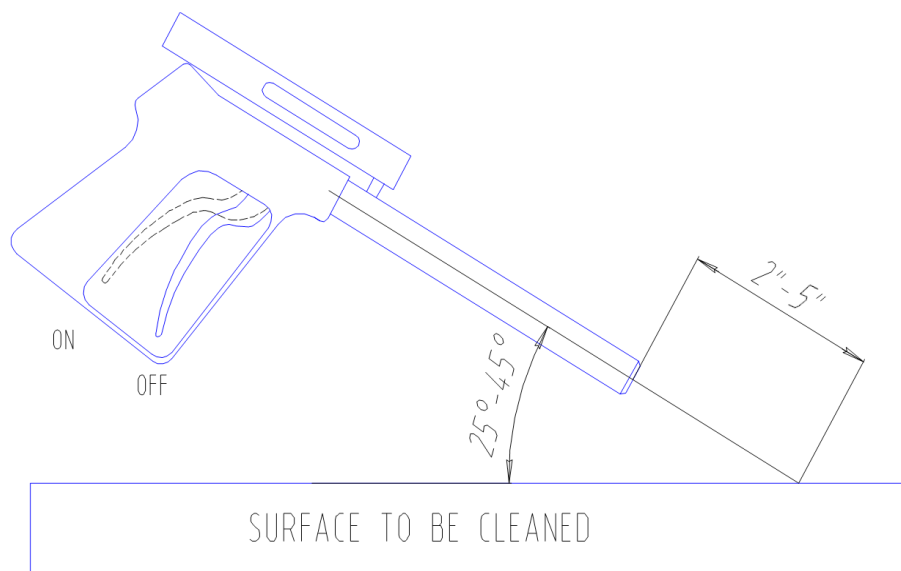

Figure 5.3 – ZT-Gun position for best results

3. Follow all safety regulations that may be applicable to the work being performed.
4. If the diver operating the CaviBlaster™ unit must be replaced or the cleaning operation must be terminated, disengage the pressure pump by pushing the throttle lever in to the idle position (Figure 5.1) and release the water pressure remaining in the hose(s) by moving the **ZT-Gun / CaviDome™** trigger to the open or "ON" position while under water. If using the **CaviBlaster™ Lance** there is no trigger to operate, it will release by itself all pressure after turning the unit OFF. Revert to step 1 of the operating instructions when the diver or replacement is ready to continue cleaning.





DO NOT PLACE YOUR HAND OR ANY OBJECT UNDER THE CaviDome™ ROTATING NOZZLES. AND DO NOT RUN OUT OF WATER.

(EOS)

6.0 MAINTENANCE

Maintenance on this unit should be restricted to authorized personal that have been properly trained. Review this manual, especially Section 3.0 SAFETY INFORMATION, prior to performing any service on this equipment.

 Equipment must be OFF prior to performing any service work.

 Only replace parts with those supplied or approved by CAVIDYNE™, LLC. Use of any other parts may lead to equipment failure and severe personal injury.

 CAVIBLASTER™ 1625-D MUST BE FLUSHED AND RINSED AFTER EACH USE IN SEA WATER.

 FAILURE TO FLUSH AND RINSE THE UNIT WILL RESULT IN PREMATURE WEAR AND TEAR ON THE COMPONENTS AND DECREASED SERVICE LIFE.

 Failure to flush and rinse the unit can cause the pump valve(s) to stick in the open position. This will prevent the system from producing the correct operating pressure.

6.1 Basic Preventive Maintenance Recommendations

	After Every Use	Monthly	Every 12 Months or 250 Hours*	Every 12 Months or 500 Hours*	Every 3 Years or 1500 Hours*
Check engine oil level and add if low	X				
Check pump oil level and add if low	X				
Check coolant level and add if low	X				
Check drive belt for wear and replace if worn	X				
Check feed pump base plate strainer and clean if necessary	X				
Check in-line strainer cartridge and clean if necessary	X				
Inspect hose for wear or damage ¹	X				
Check ZT-Gun / CaviDome™ trigger for leakage and replace if necessary ²		X			
Replace engine oil and oil filter ³			X		
Replace engine fuel filter			X		
Replace engine air filter			X		
Replace pump oil ⁴				X	
Replace power unit battery					X

* Whichever occurs first.

- 1) If any hose damage is found, replace hose immediately.
- 2) Remove ZT-Gun / CaviDome™ from water with system at operating pressure and trigger in the closed or "OFF" position. If water is leaking out of barrel or handle, the valve is worn and should be replaced.
- 3) The oil change interval should be every 125 hours if oil of a quality lower than prescribed by the manufacturer is used. See engine manufacturer's literature in the Appendix for additional recommendations.
- 4) The initial oil change should be after 50 hours. See pump manufacturer's literature in the Appendix for additional recommendations.

6.2 Diesel Engine Service

The diesel engine requires routine maintenance. Oil must be checked and changed regularly. Oil, air and fuel filters must be checked and changed regularly. For detailed information on these routine maintenance requirements as well as other service recommendations, please see the engine manufacturer's literature found in the Appendix.

6.3 Pump Service

The high pressure water pump requires minimal maintenance. The pump oil should be checked on a regular basis. **The pump crankcase holds 44 oz. (1.3 L) of SAE 30 weight non-detergent hydraulic oil.** See pump manufacturer's literature found in the Appendix for further information.

6.4 Inspection / Cleaning of water inlet strainer

The water inlet strainer should be inspected after each use of the CaviBlaster™ 1625-D. To inspect and clean this strainer, follow the procedure below:

- 1) Isolate or disconnect the water source from the inlet connection to the power unit.
- 2) Unscrew the filter housing (turn CCW) (see Fig. 6.1).
- 3) Pull filter bowl DOWN.
- 4) Remove the strainer.
- 5) Inspect the strainer and flush any debris clean with clean water.
- 6) Push strainer back into housing.
- 7) Push the bowl back onto filter housing.
- 8) Thread the housing nut CW by hand to tighten.



● Unscrew filter holder



● Pull down the case



● Inspect and clean cartridge if necessary

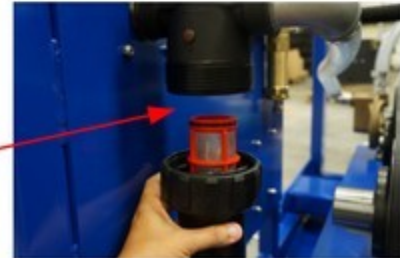

● Re insert case and screw in place

Figure 6.1 – Inspection / Cleaning Water Filter

(EOS)

7.0 WEATHERIZATION

The power unit should be winterized only if temperatures drop below 32 degrees Fahrenheit (0 degrees Celsius).

Total system displacement with 100 ft. of hose (optional): 4.3 gallons.
Total system displacement without hose: 2.0 gallons.

To winterize the CaviBlaster™ 1625-D power unit:

1. Fill a 5 gallon tank with appropriate antifreeze solution.
2. Connect the suction of the unit to the antifreeze tank.
3. Start the unit and make sure the pump is primed.
4. Attach a minimal amount of pressure hose and direct the outlet of the hose into the antifreeze tank.
5. Run the unit without ZT-Gun / CaviDome™ / Lance attached until antifreeze comes out of the end of the hose for 10 seconds.
6. Stop the unit.

Following this procedure will ensure that all the critical system components exposed to water have been flushed with antifreeze.

This space intentionally left blank

(EOS)

Page - 35

For more information please email sales@cavidyne.com or call 1-(352)275-5319

8.0 TROUBLESHOOTING

1. ENGINE DOES NOT TURN OVER

- Verify that the Emergency Stop button is released
- Verify that the battery terminals are clean and tight
- Verify battery charge
- Check the alternator belt tension

2. ENGINE TURNS OVER BUT DOES NOT START

- Check fuel level
- Check fuel filter
- Check fuel line for air lock
- Verify that fuel pump solenoid is not stuck

3. ENGINE THROTTLES UP, BUT STALLS AFTER FEW SECONDS

- Verify that drive belts are tensioned (follow procedures in Section 6.5)
- Check that pressure regulator / unloader switches to by-pass mode
- Check mechanical stop on the throttle cable if at end position

4. ENGINE SPEEDS UP, BUT WATER DOES NOT GO OUT THE CAVITATIONAL TOOL

- Verify inlet water supply
- Ensure that the power unit is not located too far above the water level, exceeding the capacity of the feed pump
- Check that feed pump and inlet water strainers are clear
- Check for leaks in the water lines
- Check for an air-lock in the water inlet lines
- Verify that the feed pump is delivering water
 - Pump mechanical failure
 - Bad electrical connections
- Check that pressure pump inlet and discharge valves are not stuck open (common problem if not flushed after use with sea water)
- Check for water going out of the bypass – pressure regulator failure

5. CaviBlaster™ UNIT OR HOSES VIBRATING EXCESSIVELY (PRESSURE PUMP STARVED)

- Verify that inlet feed water supply is adequate and functioning

- Closely inspect feed pump electrical leads for fraying, damaged insulation, corrosion buildup or otherwise compromised splices that may increase electrical resistance and reduce power to operate and reduce the electrical feed pump performance.
- Ensure that the power unit is not located too far above the feed water level, exceeding the lift capacity of the feed pump (max 5 to 6 feet lift)
- Verify that the feed pump is sufficiently submerged to prevent drawing air into the system which can cause significant damage the pressure pump and other components
- Verify that feed pump strainer and inlet water strainer are not clogged
- Check for air bubbles by observing through the clear water lines (hoses) of the unit which can cause significant damage the pressure pump and other components
- Check for air leaking or trapped in the water inlet lines (air-lock)
- Check for leaks in the water lines
- Check for excessive water going out of the bypass (regulator / unloader failure)

6. WATER IN CRANK CASE

- Check the pump seals (feeding water at greater than 50 PSI can force water past the seals and damage the seals)
- Check the plungers for cracks
- Check the plunger rod O-ring

7. AFTER RELEASING THE MECHANICAL TRIGGER, WATER IS STILL LEAKING OUT OF THE ZT-Gun / CaviDome™

- Replace the mechanical trigger valve assembly in the ZT-Gun / CaviDome™ handle.

8. ZT-Gun / CaviDome™ / Lance IS NOT CLEANING PROPERLY

- Verify that the system is operating at the correct pressure (2,500 PSI (172 BAR))
- Remove the ZT-Gun / CaviDome™ / Lance from water with the system at operating pressure and trigger in the closed or “OFF” position. If water is leaking out of the barrel or handle, the trigger valve assembly should be replaced
- Check cavitation and nozzles for foreign particles
 - Visual inspection
 - Insert a small wire into nozzle orifices to check for obstruction(s)
 - Remove trigger valve assembly and “back-flush” with compressed air or pressurized water

9.0 REPLACEMENT PARTS

CaviBlaster™ 1625-D POWER UNIT REPLACEMENT PARTS			
RECOMMENDED ORDER QTY	QTY USED PER ASSEMBLY	PART DESCRIPTION	PART NUMBER
4	2	Drive belt	2BX47
2	1	Inlet strainer cartridge	3260.02
1	1	Pressure regulator / unloader	UB 402
1	1	Pressure regulator repair kit	UB 402 / K
2	1	Engine fuel filter (Kohler)	ED002175-288-S
2	1	Engine air filter (Kohler)	ED002175-165-S
2	1	Engine oil filter (Kohler)	ED002175-265-S
2	1	Engine fuel filter (Kubota)	KUBHH160-32093
2	1	Engine air filter (Kubota)	KUB15741-11080
2	1	Engine oil filter (Kubota)	KUB7000-43801
1	1	Seal kit	UD-12
1	1	Valve kit	UD-93
1	1	Brass kit	UD-19
1	1	Plunger rod O-ring kit	UD-123
1	1	Trigger valve assembly repair kit	203300490
1	1	Feed pump base plate / strainer	54264

All parts may
be ordered
from:

CAVIDYNE™, LLC

5077 Fruitville Road
Suite 109-157
Sarasota, FL 34232 USA

Phone: (352) 275-5319

Email: sales@CaviDyne.com
www.CaviDyne.com

APPENDIX - COMPONENT LITERATURE

Electronic versions of all literature have been supplied in Adobe PDF format. The desired pages can also be accessed directly by clicking the blue underlined text links below.

Kohler Diesel Engine KDW 1404	Engine Owner's Manual Engine Service Manual Engine Troubleshooting Guide Engine Maintenance Schedule Engine Spare Parts List
Kubota V1505-E3B	Engine Owner's Manual Engine Service Manual Engine Troubleshooting Guide Engine Maintenance Schedule Engine Spare Parts List
Udor Pump NX-C-55/200R	Pump Drawing Pump Spare Parts Drawing
Relief / By-Pass valve	Valve Catalog Sheet
ZT-Gun	ZT-Gun Schematic Drawing
CaviDome™	CaviDome™ Schematic Drawing